

Manual gas bottle inspection system

The AIS202 gas bottle inspection system is especially designed to meet the needs of manufacturers who request a manual, reliable and efficient cylinder welding inspection system.

This shielded cabinet protects from X-ray radiations in compliance with the most stringent regulations: 0,5 µSv/h @ 10 cm from the surface for non professionals.

The cabinet is equipped with one large door for loading/unloading, installation and maintenance.

Our entire range of directional BALTOSPOT portable generators, driven by the CF2000 or the Hand-X control unit, can be fitted with the AIS202.



Specifications

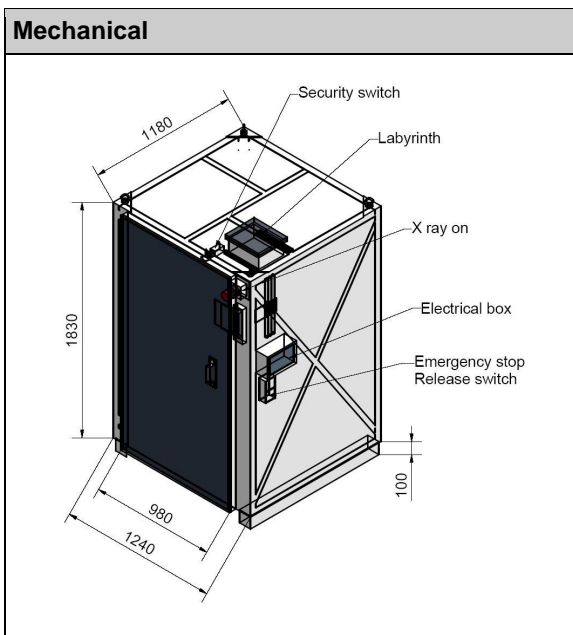

Mechanical		
Approximated overall dimensions		
Length	mm	1360
Depth	mm	1340
Height	mm	2080
Door opening		
Width	mm	800
Height	mm	1700
Approximate unloaded weight	kg	2000

Misc.	
One manual operated vertical axis, Heightened floor to be moved with a forklift truck, Swivelling door, Internal lighting, Red and orange flashing light, Door safety switch, Internal ventilation.	

Producer

Balteau NDT sa
Voie de Liège, 12
B-4681 Hermalle Sous Argenteau
BELGIUM

Tel.: +32 4 374 75 75
Fax: +32 4 374 75 85
E-mail: balteau@balteau-ndt.com
Website: www.balteau.com

Distributor

